

Recess Trim

Elevation showing joint between end and top recess trim and splice cap covering joint between two pieces of top finishing trim.

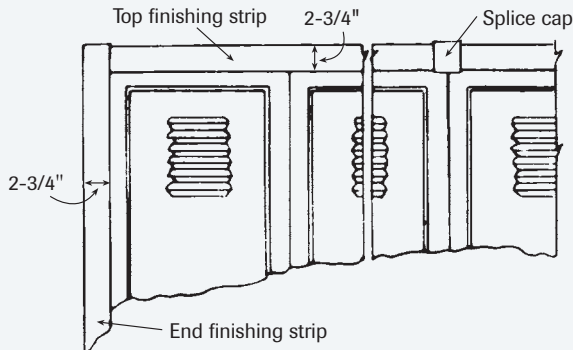

Recess Dimensions

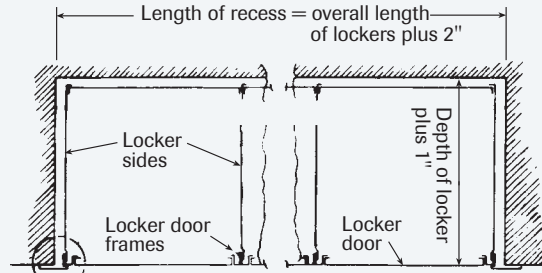

Planned section through recessed lockers showing right and left-hand end finishing strips.

Recessing Details

Vertical section through locker in recess showing recommended method of recessing. See erection instructions or shop drawings for specific locker anchoring details.

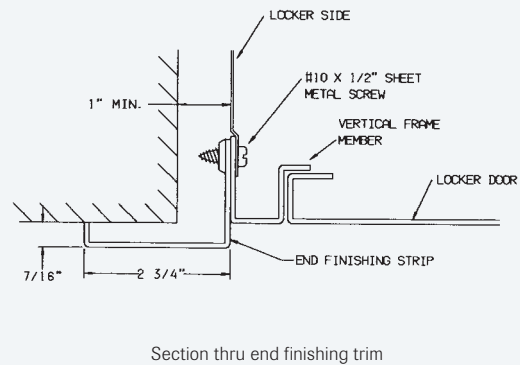
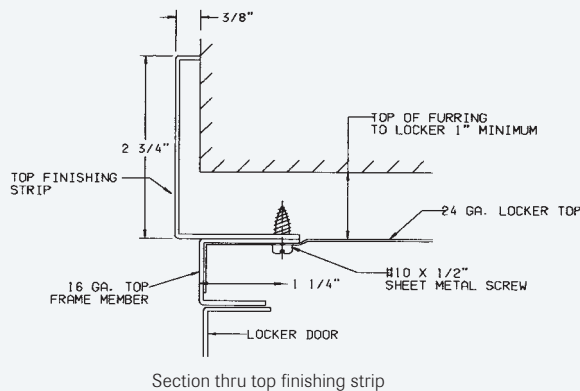

Individual Sloping Tops are furnished on lockers with full height side panels and backs.

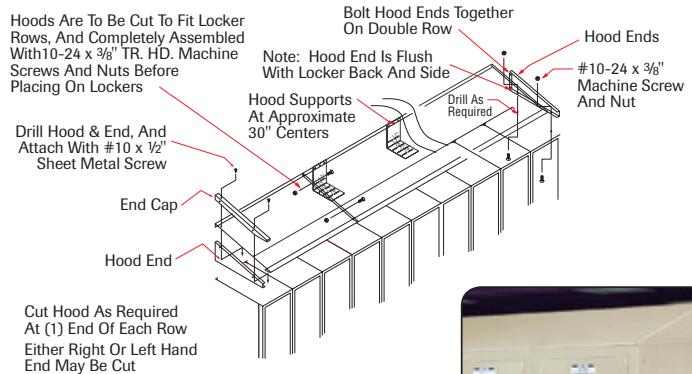
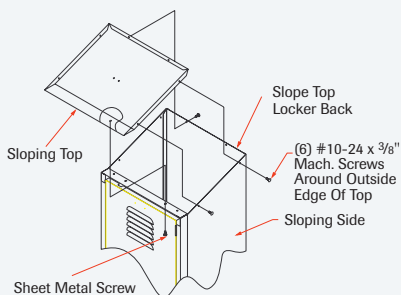

Continuous Sloping Hoods mount on one or more standard flat top lockers.