



OWNER'S MANUAL



Save This Manual For
Future Reference

CLEAN ROOM CHAIR MODEL NO. 2043CRN

DESCRIPTION

Lyon Clean Room Chair is ergonomically engineered for durability, support, comfort and long wear. Pneumatic lift allows 8" of adjustment while you are seated. Five-leg base is one-piece construction of aluminum. Five-leg base ensures maximum stability, especially critical at high height ranges. Five high-impact, non-marking glides are included. Clean room casters are available as an option.

GENERAL SAFETY INSTRUCTIONS

Do not stand on seat. Chair must be on level surface to ensure proper stability. Only use chair when fully assembled. Periodically check fasteners and tighten securely as needed. Never use chair if it does not perform according to this manual. Warranty may be void if chair is used while damaged. Immediately call and report any problems (see How to Order Repair Parts) and always give the serial number from label under seat.

PLEASE NOTE: Clean room chair you have ordered was prepared for use in controlled environments. Self-skinning closed cell foam seat and backrest are ideal for applications which require particulate cleanliness during both static and compression conditions. Manufacturer has wiped down all component parts and has sealed the sub-assemblies in nylon bags. Always follow your own internal practices in preparation of introducing the chair into the clean room.

ASSEMBLY

1. Unpack chair. Check all parts against parts list before beginning assembly. Allow parts to warm to room temperature prior to assembly.
2. Turn base upside down. Insert glide into the end of base leg and tap glide down (Key Nos. 1 and 2) using a rubber mallet. Repeat for other four glides. Turn base right side up.
3. Insert pneumatic lift (Key No. 3) into base, tapered end down. Secure the lift assembly by applying a little downward pressure.

4. Slide footring (Key No. 4) onto pneumatic lift, position at desired height. Turn footring knob (Key No. 5) to secure.
5. Install seat (Key No. 21) on top of lift. Align hole in control assembly (Key No. 9) with top of lift. Push down on seat to insert firmly together. Underneath the seat on right side is a handle to adjust height of lift.
6. Slide lower backstem (Key No. 14) into slot at back of control assembly. Use a standard screwdriver to depress push button near end of lower backstem. Slide backstem until push button locks in control. Remove knob with cone point (Key No. 13) from parts bag. Thread knob into control and tighten to secure lower backstem.
7. Slide upper backstem (Key No. 18) with backrest (Key No. 20) into lower backstem. Tighten knob with flat point (Key No. 15) to secure backrest in place.
8. Make final chair adjustments following instructions on page 4.

MAINTENANCE

The pneumatic lift is permanently lubricated at the factory and needs no further lubrication. **Never lubricate the pneumatic lift.** This could damage the lift and void your warranty.

Do not remove clip from bottom of lift. Call for immediate assistance if clip is missing or damaged. Clean polyurethane seat and backrest with soap and water. To repair cuts, apply a few drops of quick drying glue in the cut and press the sides together until glue sets.

HOW TO ORDER REPAIR PARTS

When ordering repair parts or reporting problems, always give the following information:

NAME OF ITEM	MODEL NUMBER
Clean Room Chair	2043CRN
PART DESCRIPTION	PART NUMBER

All parts listed may be ordered from your local Lyon Dealer or Lyon Workspace Products, P. O. Box 671, Aurora, IL 60507 800/323-0082 or 630/892-8941

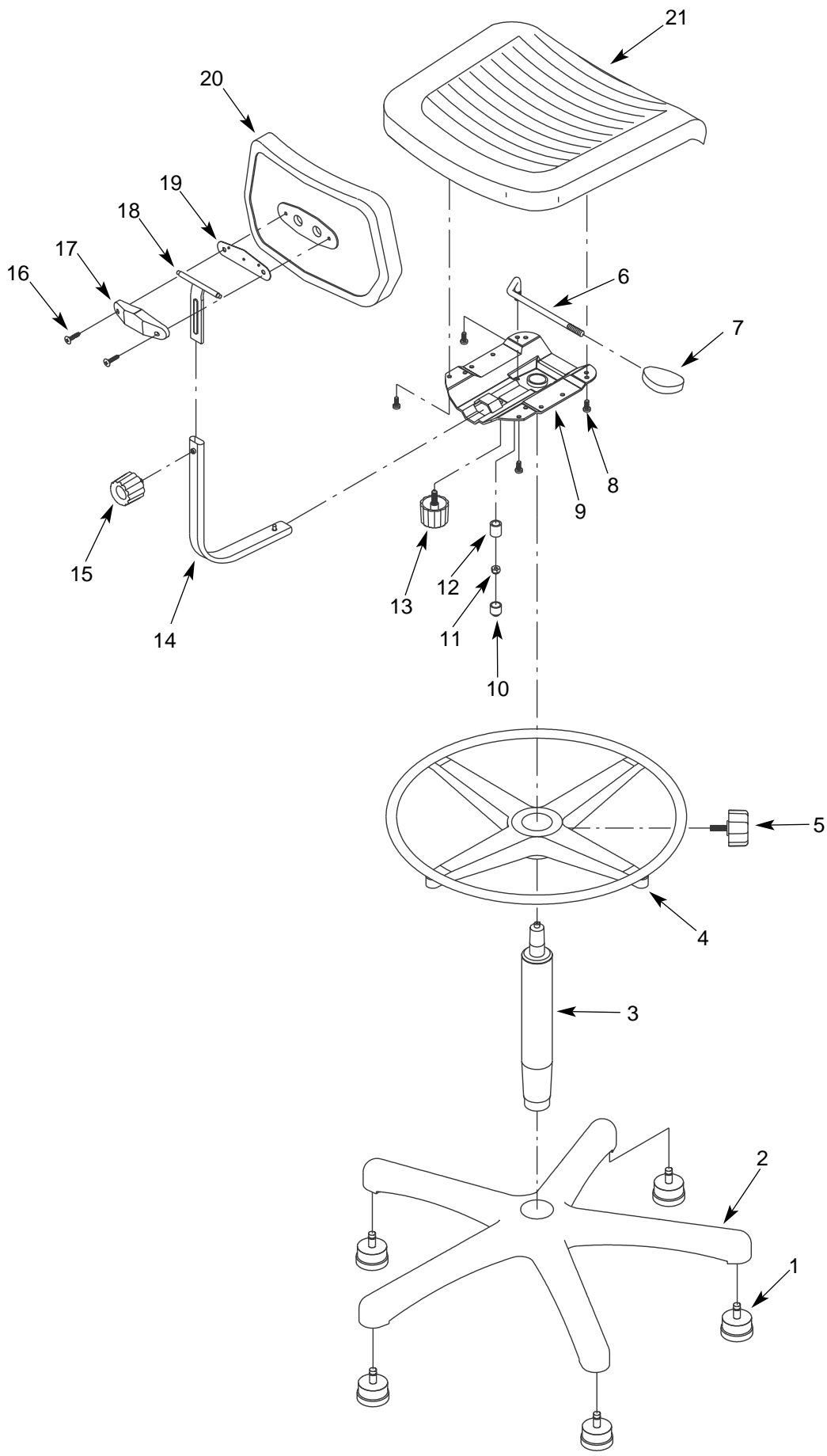

KEY NO.	DESCRIPTION	QTY	PART NO.
1	Glide	5	09100.00
2	Base	1	01800.00
3	Pneumatic Lift	1	03267.52
4	Footring with Knob	1	09005.00
5	Footring Knob	1	09005.02
6	Lever	1	09041.03
7	Handle	1	03394.02
8	6-1.0 x 16mm Pan Head Screw	4	03713.00
9	Control Assembly (includes Key Nos. 7, 8 and 10-13)	1	03247.06
10	Cap	1	10196.00
11	8-1.25mm Jam Nut	1	01256.02
12	Bushing	1	01235.04
13	Knob with Cone Point	1	01266.02
14	Lower Backstem	1	01748.02
15	Knob with Flat Point	1	03408.01
16	6-1.0 x 26mm Oval Head Screw	2	03714.00
17	Backstem Cover	1	01269.02
18	Upper Backstem	1	03406.02
19	Backing Plate	1	03405.01
20	Backrest	1	01271.06 CR
21	Seat	1	01267.06 CR

OPTIONAL ACCESSORY	
Clean Room Caster	2071

CHAIR ADJUSTMENT INSTRUCTIONS

To maximize ergonomic benefits of this chair, it is essential to understand how controls function and how they affect your posture.

SEAT HEIGHT ADJUSTMENT

Sit centered in seat. Locate handle (Key No. 7) under seat and pull up. Ease weight up or down until you have reached the height you want, and release lever. The proper height is determined by a combination of : height of work surface, task performed and body size. Chair should be high enough so arms form 90° angle at the elbow or slightly greater. This allows better circulation in shoulders and neck area and reduces fatigue in forearms and hands. Feet should be flat on ground or footrest. Maintain a 90° angle at bend of knees.

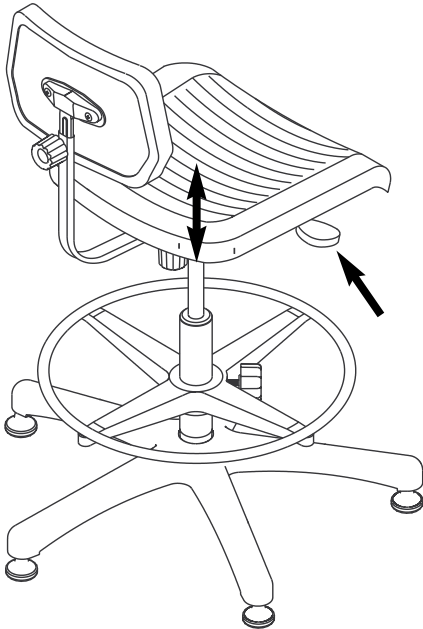

BACKREST HEIGHT ADJUSTMENT

Loosen knob (Key No. 15) behind backrest. Adjust backrest until curve fits into small of your back. This will reduce pressure on the spinal discs, especially in lumbar area. Retighten knob.

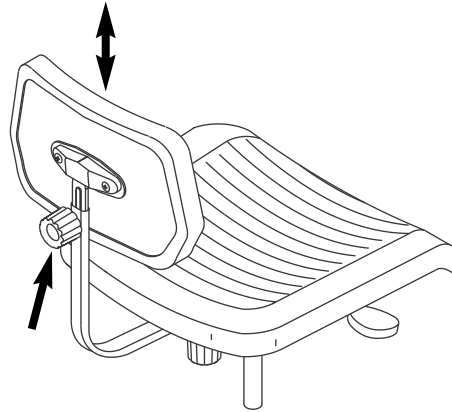

BACKREST DEPTH ADJUSTMENT

Adjustment knob (key No. 13) is located under seat just behind pneumatic lift. Loosen knob to slide backrest into position. Allow surface of backrest to help support upper body weight by positioning backrest in curve of your spine. This will reduce pressure on the spinal discs, especially in lumbar area. Backrest should tilt freely to enable support in various positions. Tighten knob.

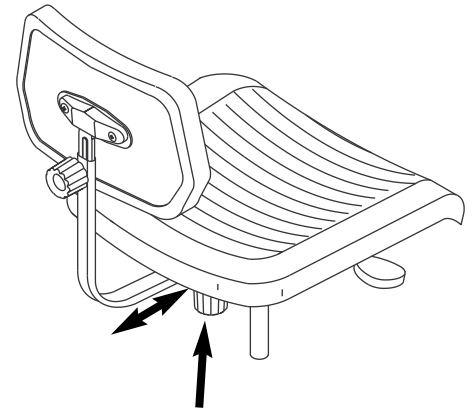

WARRANTY

Lyon Workspace Products warrants all of its products to be free from manufacturing defects for the life of the product when it is used in accordance with manufacturer's specifications and/or operating instructions. The life of the product is ten years of single shift users, five years for two shift users, and two-and-a-half years for three shift users, for users not weighing more than 250 pounds.

During this period Lyon Workspace Products will repair or replace, at its option, any part found upon examination to be defective. Freight, labor or service charges for removal of defective parts and installation of replacement parts are not included. **All parts that are replaced due to wear, misuse or abuse are not covered by the warranty but replacement parts can be purchased from Lyon Workspace Products.**

This warranty applies to the original purchaser, and the purchaser's sole remedy under this warranty is limited to replacement or repair of the product and specifically excludes consequential, incidental or any other damages directly or indirectly resulting from a failure or loss of use of or by Lyon Workspace Products.

To obtain warranty service, a return authorization by Lyon Workspace Products must accompany all returned merchandise.

Contact your Lyon Dealer or Lyon Workspace Products, P.O. Box 671, Aurora, IL 60507, 800/323-0082 or 630/892-8941.