

OPERATION #1

FASTEN TWO PIECE BACKS TOGETHER WITH NO. 1 BOLTS AND NO. 3 NUTS (8) REQUIRED ON 72" HIGH (6) REQUIRED ON 42" HIGH

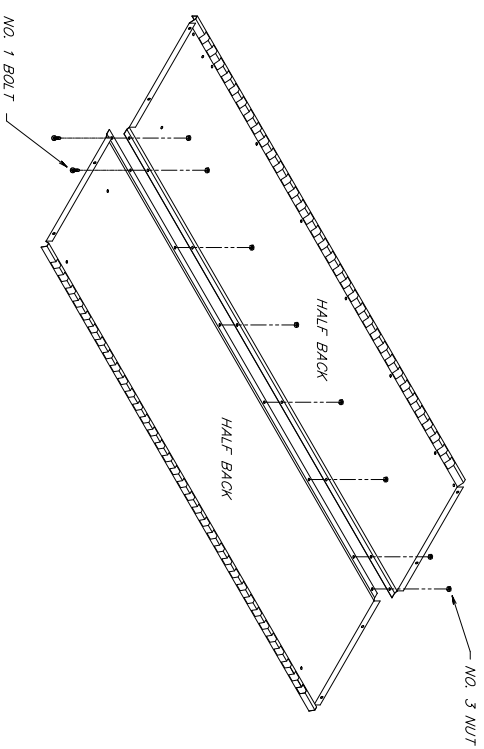

OPERATION #2

72" HIGH CABINET ATTACH CABINET TOP TO BACKS WITH (4) NO. 1 BOLTS AND NO. 3 NUTS ASSEMBLE CABINET SIDES TO CABINET BACK AND TOP WITH (20) NO. 1 BOLTS AND NO. 3 NUTS

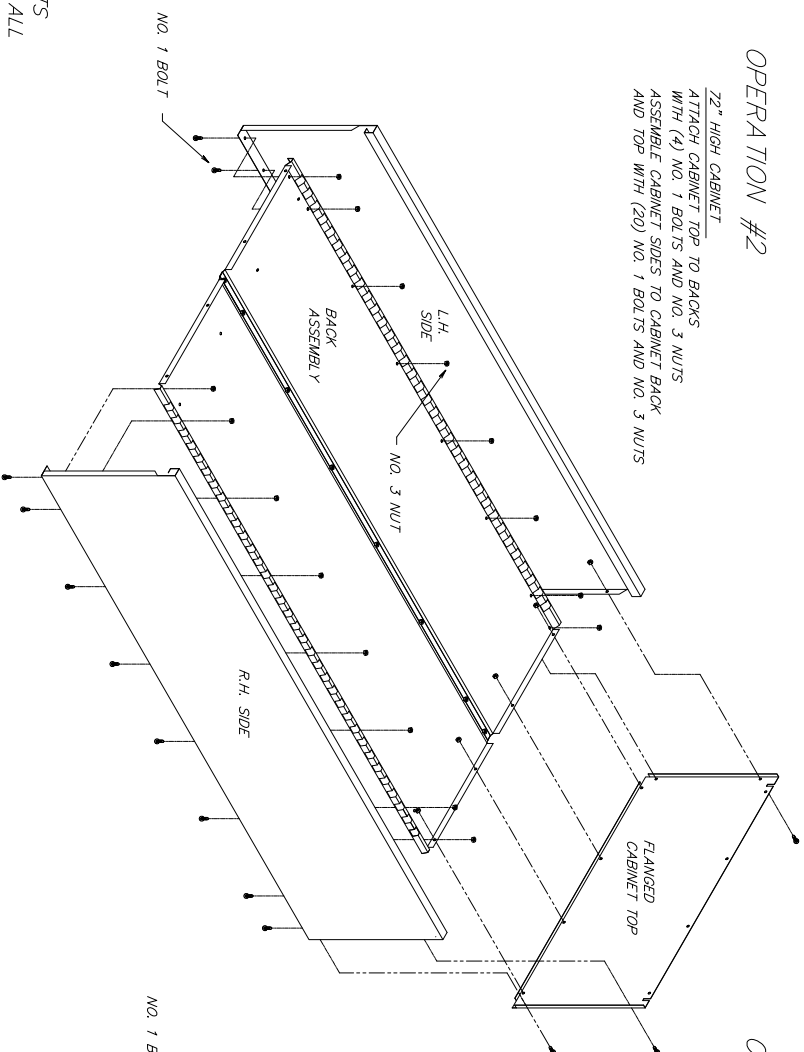

OPERATION #2

42" HIGH CABINET ATTACH CABINET TOP TO BACKS WITH (4) NO. 1 BOLTS AND NO. 3 NUTS ASSEMBLE CABINET SIDES TO CABINET BACK AND TOP WITH (16) NO. 1 BOLTS AND NO. 3 NUTS

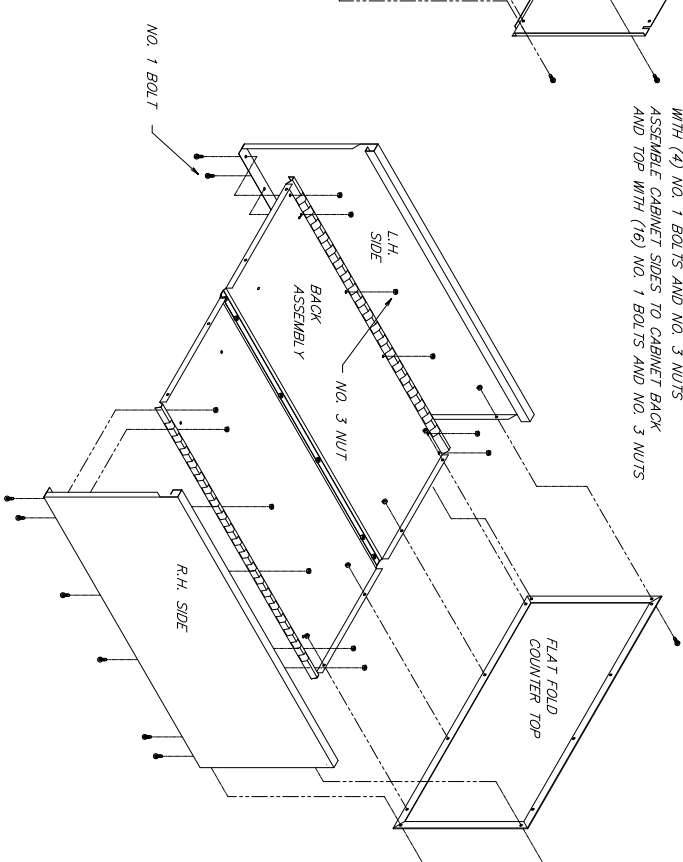

NOTE: DO NOT TIGHTEN BOLTS AND NUTS UNTIL STEP 3 IS COMPLETE AND ALL TOP AND BOTTOM SURFACES ARE EVEN.

OPERATION #3

ATTACH BOTTOM CHANNEL TO SIDES WITH (4) NO. 4 BOLTS AND NUTS. ATTACH TOP CHANNEL TO SIDES WITH (2) NO. 4 BOLTS AND NUTS. SEE DETAIL 'C'.

ALSO ATTACH TOP CHANNEL TO CABINET TOP WITH (4) NO. 1 BOLTS AND NO. 3 NUTS.

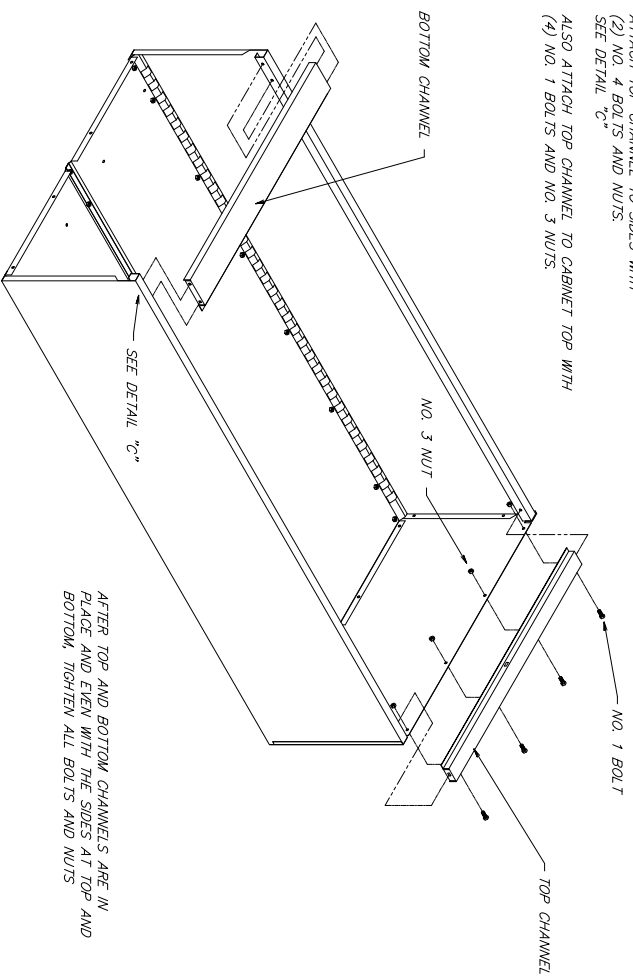

AFTER TOP AND BOTTOM CHANNELS ARE IN PLACE AND EVEN WITH THE SIDES AT TOP AND BOTTOM, TIGHTEN ALL BOLTS AND NUTS

OPERATION #4

FASTEN CABINET BOTTOM TO BOTTOM CHANNEL AND BACK WITH (8) NO. 1 BOLTS AND NO. 3 NUTS

NOTE: 3/4" FLANGE IS LOCATED IN FRONT OF CABINET

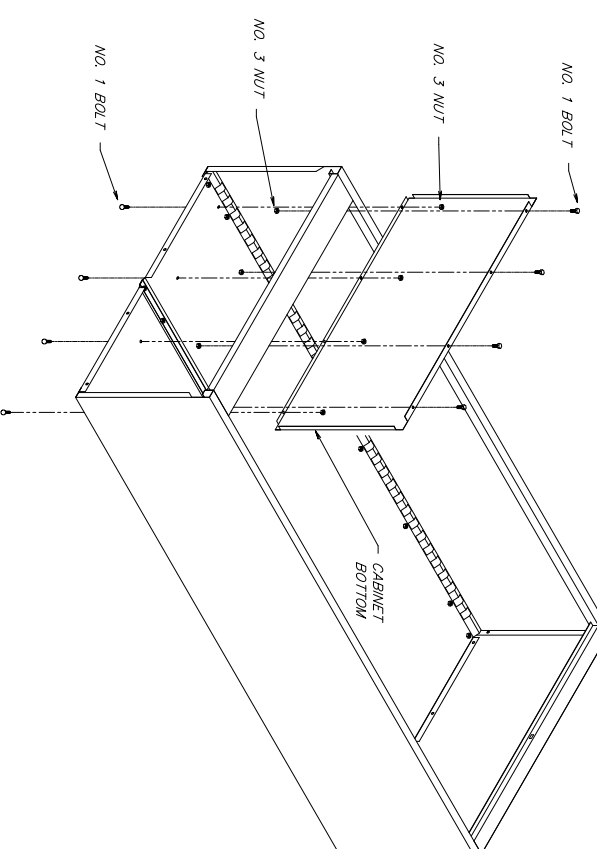

HARDWARE:

-  NO. 1 BOLT #10-24 x 3/8"
-  NO. 2 BOLT #10-24 x 7/16"
-  NO. 3 NUT #10-24
-  NO. 4 BOLT AND NUT 1/4-20x5/8" BOLT W/ LOCKWASHER AND KEP NUT
-  NO. 5 SCREW 8-32 x 1/4" ROUND HEAD W/ LOCKWASHER
-  NO. 6 SCREW 8-32 x 1/4" FLAT HEAD COUNTERSUNK
-  NO. 7 WASHER #8 SAE FLAT WASHER
-  DOOR PLASTIC GROMMET
-  SHELF BRACKET

CONTINUED ON
BACK SIDE
OF THIS SHEET

OPERATION #5

DOOR ASSEMBLY:
SNAP IN (1) PLASTIC LOCKBAR GROMMET IN
TOP AND BOTTOM OF DOOR
SEE DETAIL "A"

FASTEN HANDLE TO DOOR WITH (2) NO. 5 SCREWS
PUT (2) NO. 7 WASHERS ON LOCKING CAM, FOLLOWED BY
THE LOCKBARS AND THEN THE BACKING PLATE
ATTACH ASSEMBLY TO HANDLE WITH (1) NO. 6 SCREW

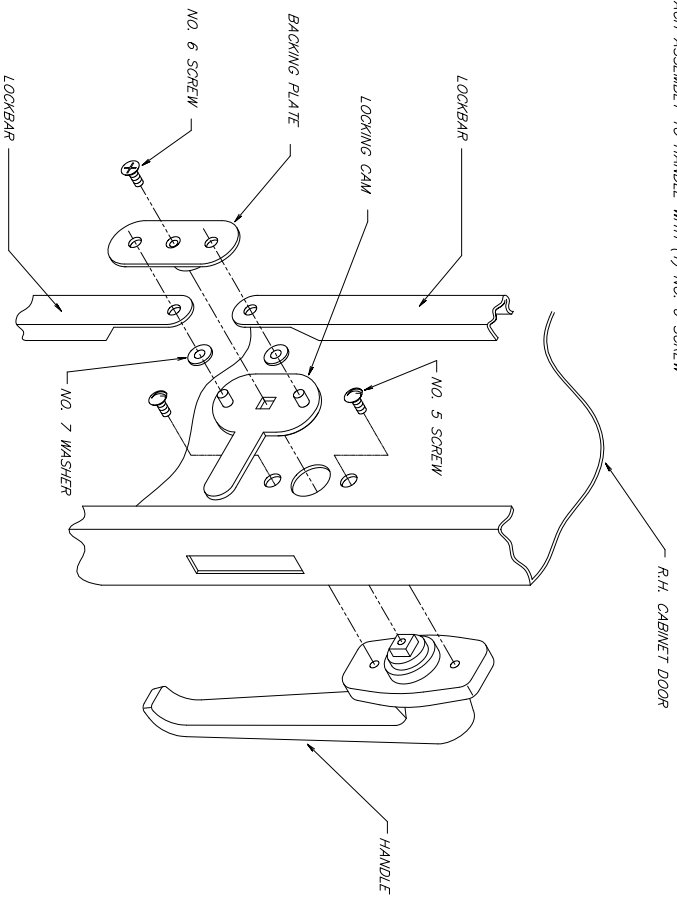

OPERATION #6

LIFT CABINET UPRIGHT AND ATTACH DOORS TO
CABINET WITH (6) NO. 2 BOLTS AND NO. 3 NUTS
SEE DETAIL "B"

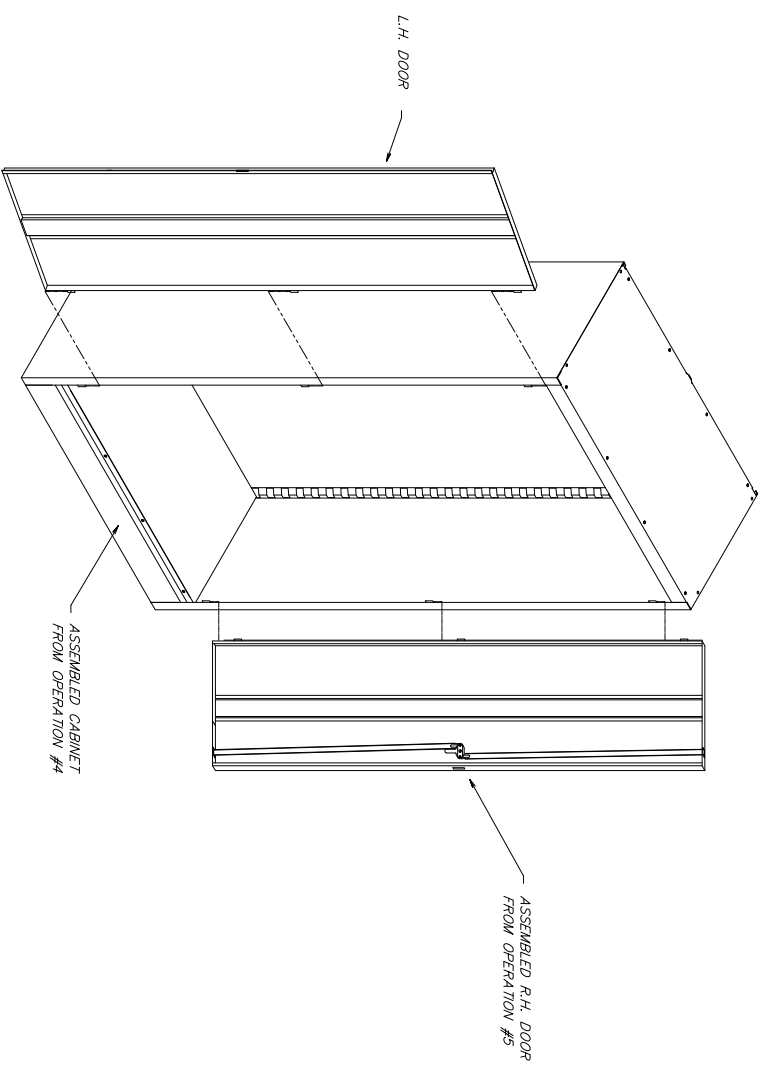

OPERATION #7

INSERT SHELF BRACKETS AT DESIRED SHELF SPACING

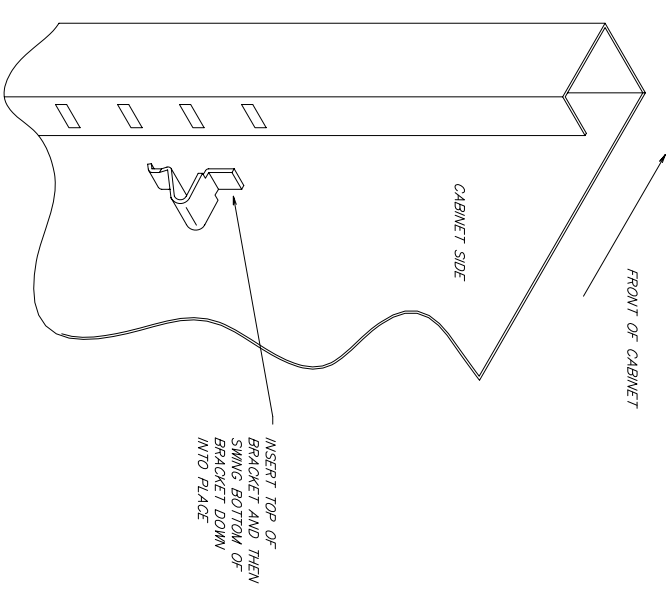

OPERATION #8

INSTALL SHELVES INTO CABINET
BY PLACING REAR OF SHELF INTO SLOTS
IN CABINET BACK AND ALLOWING FRONT OF SHELF
TO REST ON SHELF BRACKETS IN FRONT.

NOTE: SHELF SLOTS IN BACK ARE ON 2" CENTERS
AND SHELF BRACKET SLOTS ARE ON 1" CENTERS.
BE SURE SHELVES ARE LEVEL.

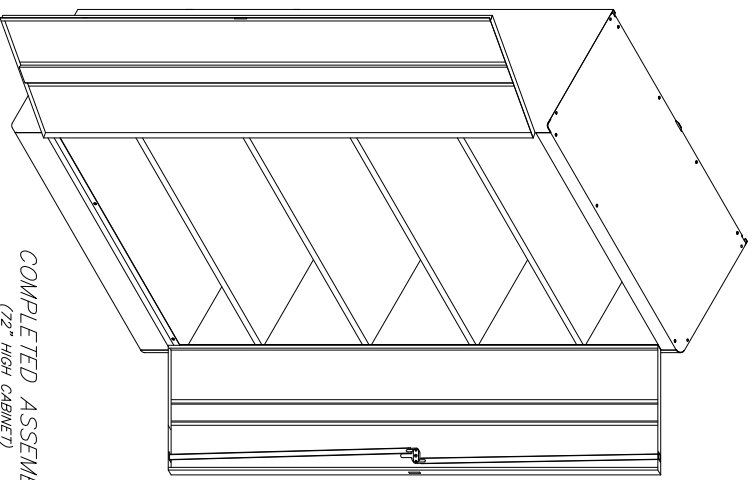

DETAILS:

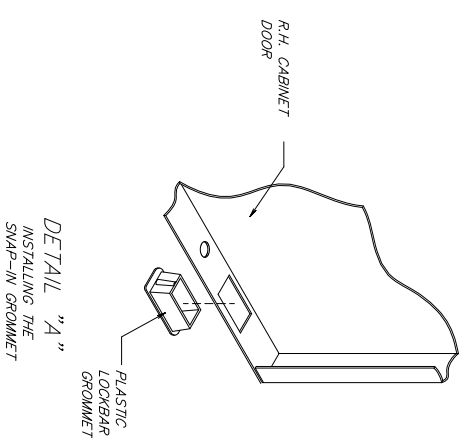

DETAIL "A"
INSTALLING THE
SNAP-IN GROMMET

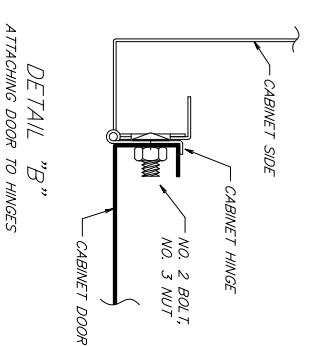

DETAIL "B"
ATTACHING DOOR TO HINGES

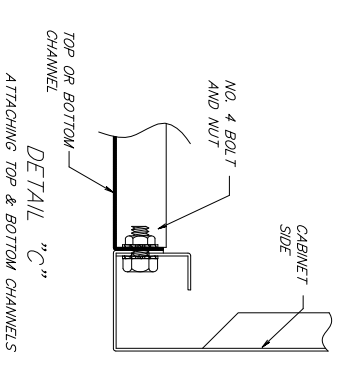

DETAIL "C"
ATTACHING TOP & BOTTOM CHANNELS