

DOUBLE ROW, FLAT TOP LOCKERS

GENERAL INSTRUCTIONS:

- 1) PLEASE READ COMPLETE ASSEMBLY INSTRUCTIONS BEFORE ATTEMPTING TO ASSEMBLE LOCKERS. FOR ACCESSORIES, SEE SHEET 3 IN THE SINGLE ROW LOCKER ASSEMBLY INSTRUCTION, 6225-CA.
- 2) CHECK THE MATERIAL TO BE SURE THAT IT IS CORRECT FOR THE JOB AND THAT THERE IS NO DAMAGE.
- 3) BE CAREFUL TO USE THE CORRECT HARDWARE SPECIFIED. USE BOLT NO. 1 ALL AROUND WITH BOLT HEADS OUT EXCEPT AS NOTED.
- 4) LOCKERS SHOULD BE ASSEMBLED IN GROUPS AS INDICATED ON THE ORDER OR DRAWINGS.
- 5) THE ESSENTIAL TOOLS REQUIRED FOR ASSEMBLING LOCKERS ARE: A REGULAR SCREWDRIVER, TWO DRIFT PINS (OR TWO NAIL PUNCHES) FOR HOLE ALIGNMENT, AND A 3/8" SOCKET WRENCH.
- 6) LOCKERS SHOULD BE ASSEMBLED ON A FLAT LEVEL SURFACE AND ANCHORED PER SHEETS 5 & 6 OF 6225-CA.

HARDWARE:



LOCK HOLE
FILLER

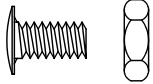

NO. 1 SLOTLESS
BOLT & NUT
#10 X 3/8"
ROUND HEAD

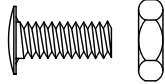

NO. 2 SLOTLESS
BOLT & NUT
#10 X 1/2"
ROUND HEAD

NOTE: FOR HEAVY DUTY LOCKERS, USE NO.2 BOLT ONLY.

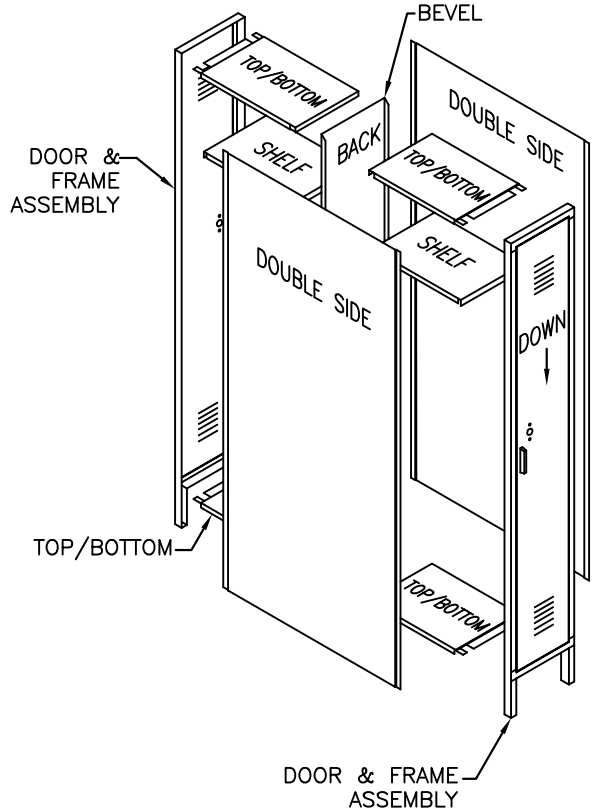

OPERATION #1

BOLT 2 TOPS AND 2 BOTTOMS (IDENTICAL) WITH FLANGES DOWN TO A BACK (WITH BEVEL EDGE UP).

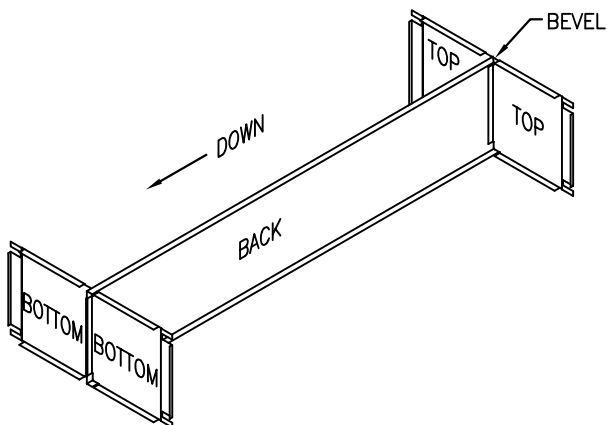

OPERATION #2

ATTACH THE OPERATION #1 ASSEMBLY TO A DOUBLE ROW SIDE WITH THE OFFSET IN. BOLT THE BACK TO THE SIDE. BOLT 2 SHELVES AT DESIRED LOCATION (E.G. 9", 12", ETC.) TO THE SIDE WITH FLANGES DOWN & 45° FLANGE IN FRONT.

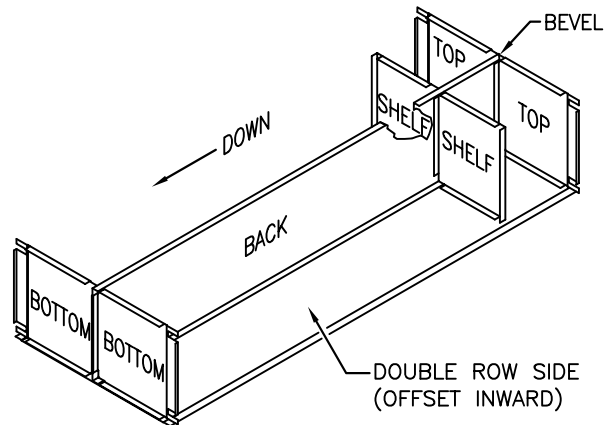

E-010120-2

MISSING PARTS OR IN NEED OF ASSEMBLY ASSISTANCE?

Contact us direct for fast friendly service (800) 433-8488

Int'l calls (630) 892-8941 | WEB: WWW.LYONWORKSPACE.COM | Fax (800) 367-6681

ASSEMBLY INSTRUCTIONS
FOR LYON DOUBLE ROW
FLAT TOP STEEL LOCKERS

LYON LYON WORKSPACE PRODUCTS
P.O. BOX 671
501 201 AURORA, IL 60507

6227-CA

SHEET 1 OF 2

OPERATION #3

1) BOLT THRU SHELF, TOP, BOTTOM AND BACK WITH SIDE BETWEEN USING NO. 1 BOLT. REPEAT FOR DESIRED NUMBER OF OPENINGS. ADD A LAST DOUBLE ROW SIDE WITH OFFSET IN TO THE ASSEMBLY.

2) PLACE A DOUBLE PRONG COAT HOOK UNDER EACH SHELF AND ATTACH SINGLE PRONG COAT HOOKS TO SIDES AND BACKS (USE NO. 2 BOLTS FOR HOOKS TO BE PLACED BACK TO BACK ON SIDES AND BACKS). ATTACH COAT RODS IF REQUIRED (SEE ACCESSORIES).

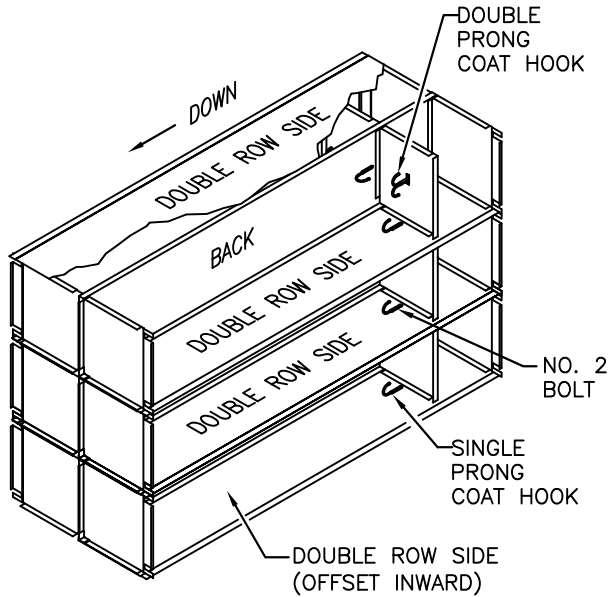

OPERATION #4

STAND OPERATION #3 ASSEMBLY UPRIGHT. TILT BACK AND BRACE UNIT. ATTACH DOOR AND FRAME ASSEMBLIES BEING SURE THE SIDE IS NEVER BETWEEN FRAMES (SEE SECTION A-A). LEAVE TOP, CENTER AND BOTTOM BOLTS OUT ON EXTREME ENDS OF GROUPS FOR ATTACHING FILLERS OR ADDITIONAL GROUPS. USE DRIFT PINS (OR NAIL PUNCHES) TO ALIGN TOP & BOTTOM HOLES OF FRAME.

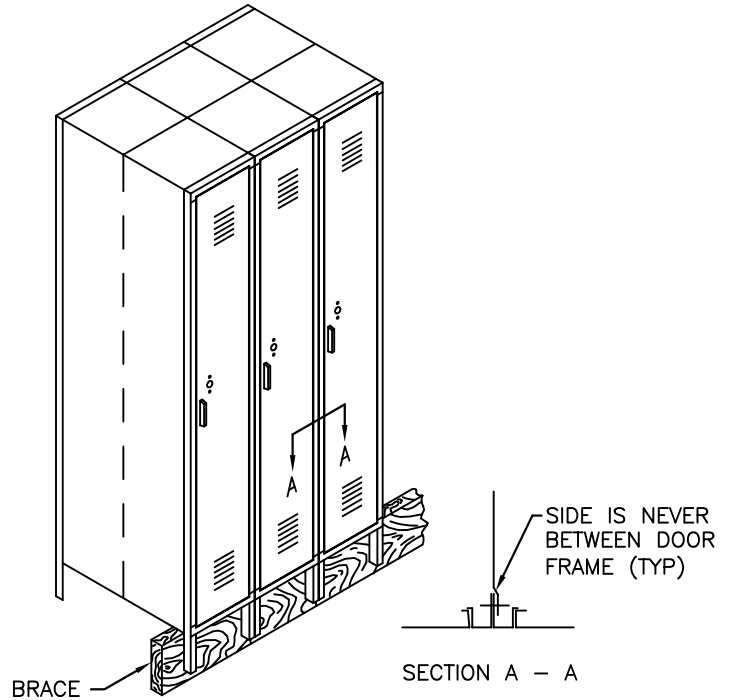

OPERATION #5

STAND GROUPS IN PLACE. BOLT GROUPS TOGETHER USING BOLTS OMITTED IN OPERATION #4. ATTACH LOCK HOLE FILLERS AS REQUIRED.

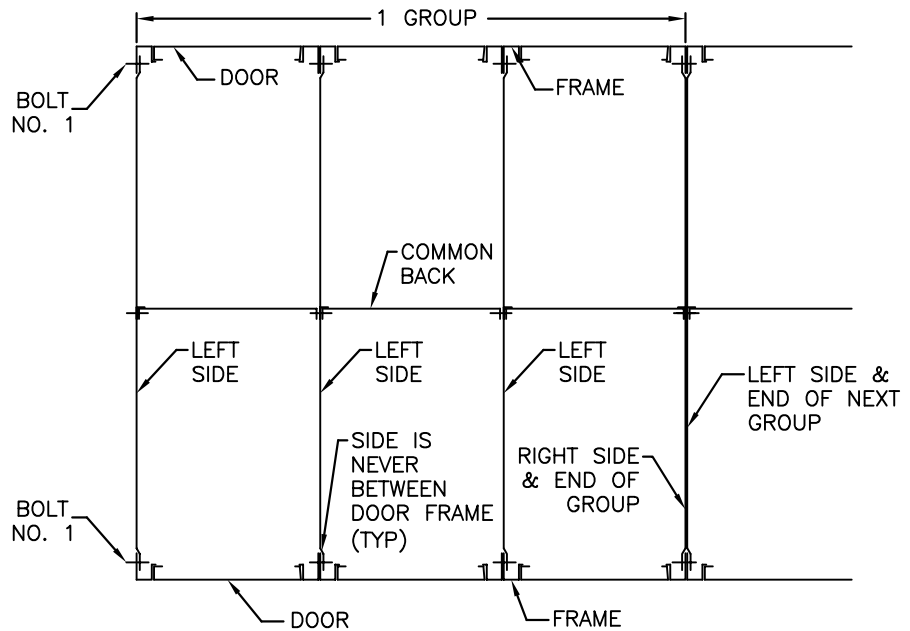

ADJACENT DOOR FRAMES OF GROUPS

E-010120-2

**MISSING PARTS OR IN NEED
OF
ASSEMBLY ASSISTANCE?**

Contact us direct for fast friendly service (800) 433-8488

Int'l calls (630) 892-8941 | WEB: WWW.LYONWORKSPACE.COM | Fax (800) 367-6681

ASSEMBLY INSTRUCTIONS
FOR LYON DOUBLE ROW
FLAT TOP STEEL LOCKERS

LYON LYON WORKSPACE PRODUCTS
P.O. BOX 671
AURORA, IL 60507

6227-CA

SHEET 2 OF 2